

 **Treadway**[®]
Equipped

STEINER
ST 240 TYRE
CHANGER



The ST240 Tyre Changer with its simple and practical design is excellent value and can meet the needs of regular tyre service. It is an entry level machine with simple swing arm action for low to mid volume.

STEINER[™]

Helping you do your job
the best way you can.

Steiner ST240 Tyre Changer

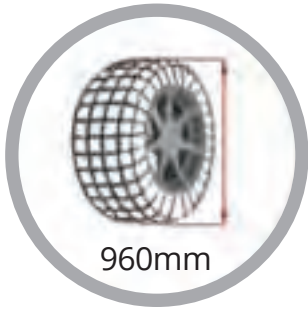

960mm

Maximum Wheel Diameter

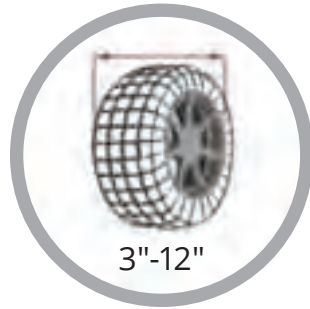

3"-12"

Rim Width

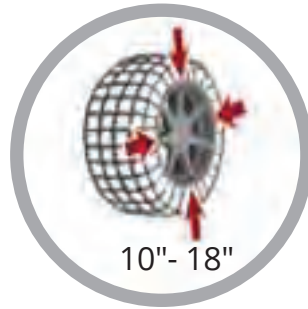

10"- 18"

Rim Clamping from outside



12"-21"

Rim Clamping from inside

Standard Equipment:

- Tyre Lever
- Pressure Gauge
- Plastic Covers
- Paste Bucket

Optional Extras:

- Plastic Mounting Head
- Clamp adaptors for 8" Wheels

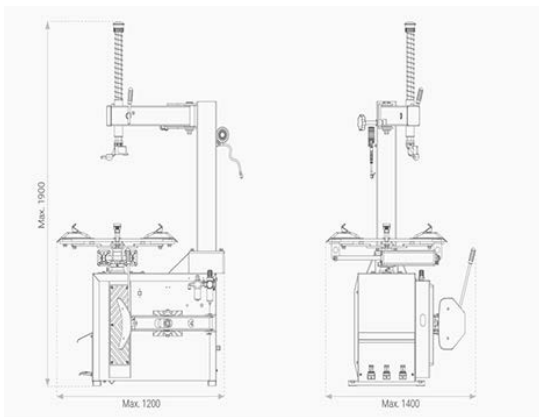

Technical Features:

› Power Supply	110V/220V/380V
› Rim clamping from outside	10" - 18"
› Rim clamping from inside	12" - 21"
› Maximum wheel diameter	960mm
› Rim width	3"-12"
› Operating pressure	8-10 bar
› Motor Power	0.85kW
› Noise Level	<70dB
› Single phase motor	

Measurements:

› Dimensions	1400mm x 1200mm x 1900mm
› Weight	179kg

STEINER™